



Application

Electropneumatic linear actuators for attachment to Type 3214 and Type 3260 Valves as well as Series V2001 Valves

Rated travel	15 and 30 mm
Actuator area	120 and 350 cm²

The Type 3372 Electropneumatic Actuator is available in the following versions:

- Version **with integrated i/p converter, 120 cm²** actuator area and 15 mm rated travel (Fig. 1)
- Version **with Type 3725 Positioner (direct attachment), 120 cm²** actuator area and 15 mm rated travel (Fig. 2)
- Version **with Type 3725 Positioner (direct attachment), 350 cm²** actuator area and 15 or 30 mm rated travel (Fig. 3)

The actuators are suitable for attachment to Series V2001 Valves (e.g. Type 3321, Type 3323, Type 3531, Type 3535) as well as Type 3214 and Type 3260 Valves. The actuators mainly consist of two diaphragm cases, a rolling diaphragm and internal springs. The Type 3372 Electropneumatic Actuator is controlled by a 4 to 20 mA signal. For throttling service, an i/p converter is integrated into the actuator or a Type 3725 Positioner is mounted to the rod-type yoke using a support element.

Further versions

- **Permissible operating temperatures from -35 to +90 °C** · Only when a positioner is mounted
- **Explosion protection** for a mounted Type 3725 Positioner · II 2G Ex ia IIC T4 according to ATEX, intrinsically safe Ex ia IIC T4 according to CSA Group, 1Ex ia IIC T4 Gb X according to GOST

Accessories

- **Type 4744-2 Limit Switch** (Fig. 4) · With explosion protection II 2G Ex db IIC T6-T5 and degree of protection IP 66 · Clamping plate can be used to mount it · See Data Sheet ▶ T 8367

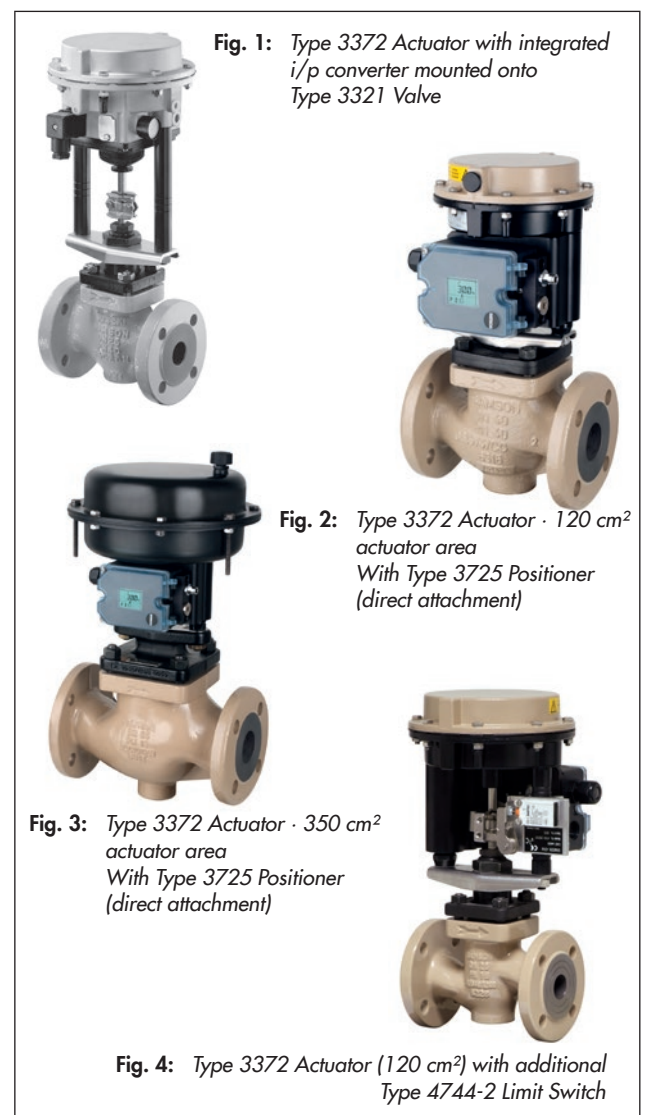

Fig. 1: Type 3372 Actuator with integrated i/p converter mounted onto Type 3321 Valve

Fig. 2: Type 3372 Actuator · 120 cm² actuator area With Type 3725 Positioner (direct attachment)

Fig. 3: Type 3372 Actuator · 350 cm² actuator area With Type 3725 Positioner (direct attachment)

Fig. 4: Type 3372 Actuator (120 cm²) with additional Type 4744-2 Limit Switch

Principle of operation (actuator with integrated i/p converter)

A control signal issued by the controller. This control signal is transmitted as a reference variable from 4 to 20 mA to the i/p converter where it is converted into a proportional pressure signal. This pressure signal creates a force that acts on the measuring diaphragm. This force is then compared with the force of the range spring. The movement of the measuring diaphragm is transmitted by the lever to the force switch to produce a corresponding signal pressure.

A change in input signal causes the actuator stem to move to the position determined by the reference variable. The flow rate through the valve changes accordingly.

Principle of operation (actuator with mounted positioner)

Details on principle of operation are described in the Data Sheet ▶ T 8394 for Type 3725 Positioner.

Tight-closing function

The electropneumatic actuator is completely filled with air or vented as soon as the reference variable falls below or exceeds a certain value.

Actuator stem extends (FA)

When the reference variable falls below the switching point of 4.08 mA, the actuator is fully vented. This causes a mounted globe valve to close. In three-way valves, port **B** is closed when the valve is used for mixing service and port **A** is closed when the valve is used for diverting service.

Actuator stem retracts (FE)

When the reference variable exceeds the switching point of 19.95 mA, the actuator is filled with air. This causes a mounted globe valve to close. In three-way valves, port **A** is closed when the valve is used for mixing service and port **B** is closed when the valve is used for diverting service.

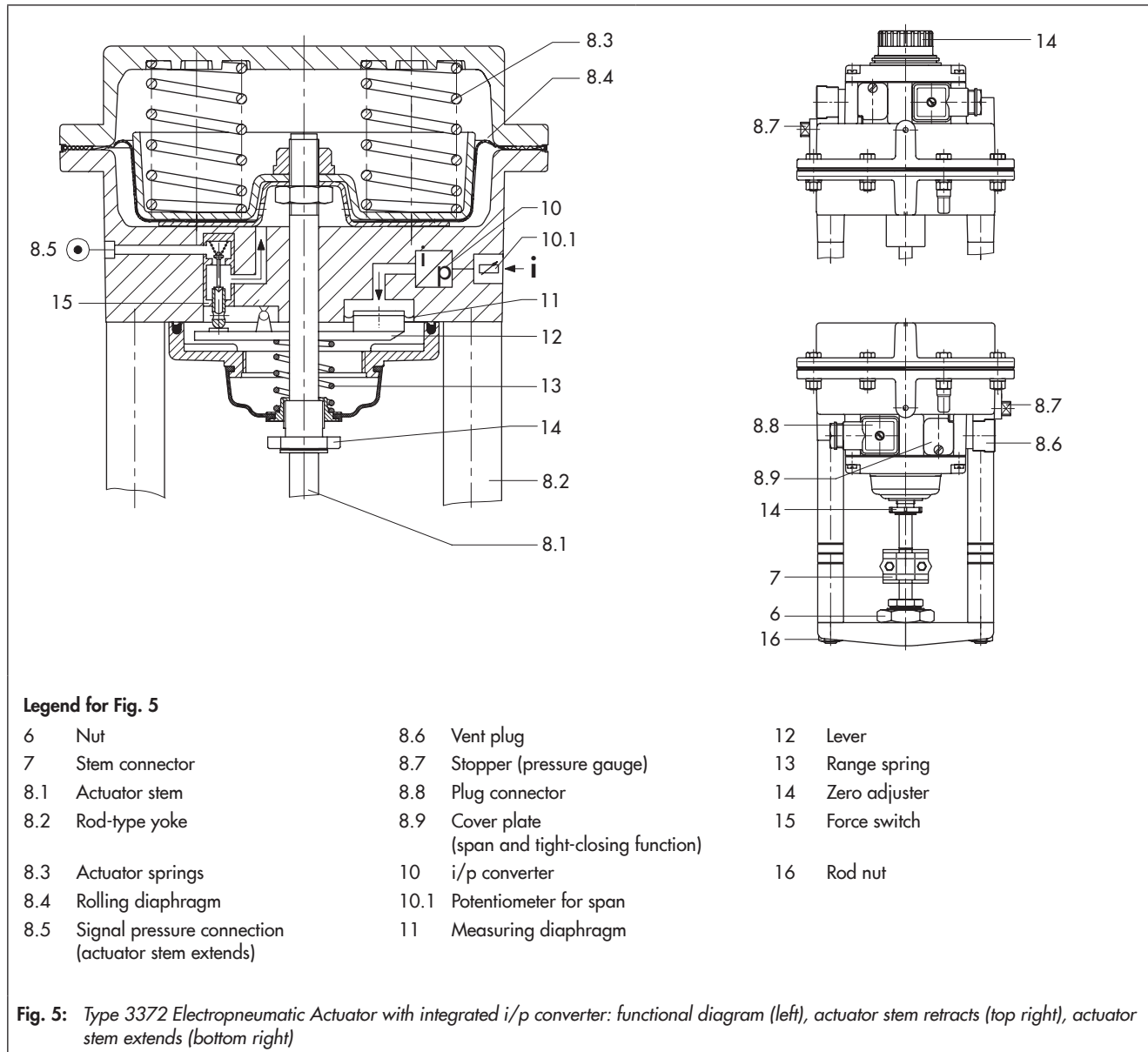

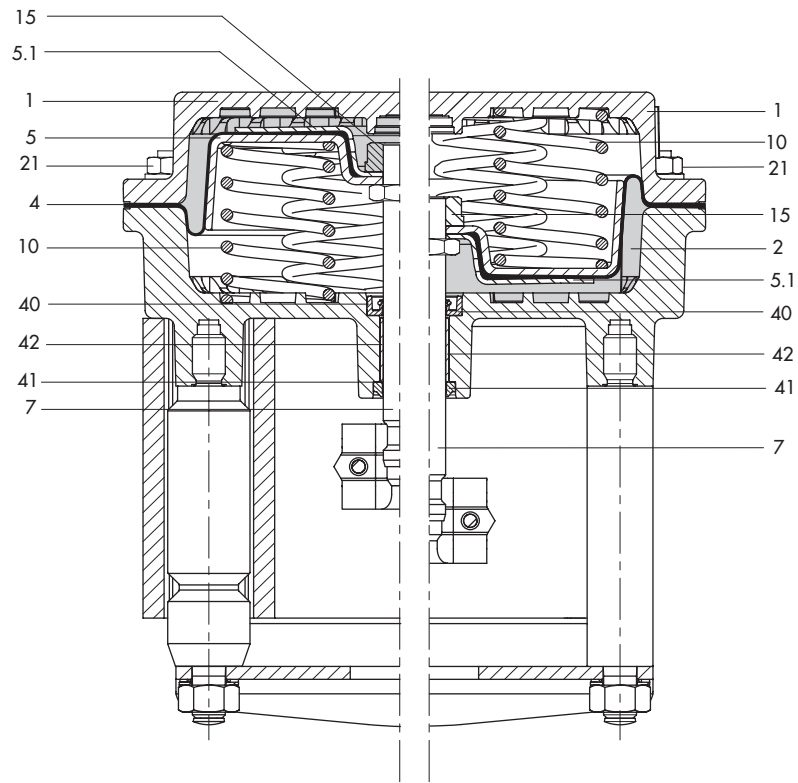

Fig. 6: Type 3372 Electropneumatic Actuator with 120 cm² actuator area for the direct attachment of a Type 3725 Positioner

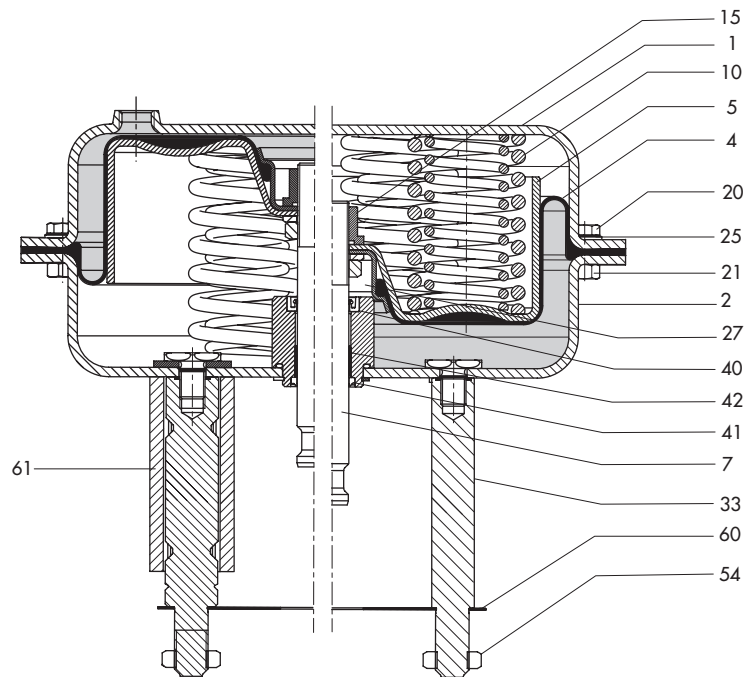

Fig. 7: Type 3372 Electropneumatic Actuator with 350 cm² actuator area for the direct attachment of a Type 3725 Positioner

Legend for Fig. 6 and Fig. 7

1, 2	Diaphragm case	20	Hex screw	41	Wiper ring
4	Diaphragm	21	Hex nut	42	Plain bearing
5	Diaphragm plate	25	Washer	54	Hex nut (for 33)
7	Actuator stem	27	Compressor	60	Plate
10	Spring	33	Rod	61	Support element
15	Collar nut	40	Radial shaft seal		

Table 1: Technical data

Table 1.1: Electric data of Type 3372

Type 3372	With integrated i/p converter		With Type 3725 Positioner (direct attachment) ¹⁾		
	120 cm ²		120 cm ²	350 cm ²	
Rated travel	15 mm		15 mm	15 mm	30 mm
Function (mounted device)	Conversion of a DC signal into a pneumatic output signal for measuring and control tasks		Electropneumatic positioner with self-calibrating, automatic adaptation to valve and actuator		
Reference variable	4 to 20 mA (reverse polarity protection)		4 to 20 mA (reverse polarity protection)		
Split-range operation	-		4 to 11.9 mA and 12.1 to 20 mA		
Static destruction limit	<-2 V or >+7 V		±33 V		
Minimum current	3.6 mA		3.8 mA		
Load impedance	≤7 V (300 Ω at 20 mA)		Max. 6.3 V		
Span adjustment	25 % of travel range using potentiometer		Self-adjusting		
Direction of action	Increasing/increasing, fixed		Adjustable: increasing/increasing or increasing/decreasing		
Tight-closing function	Stem extends: deactivation at ≤4.08 mA (≤0.5 %)		w < 1 % and w > 99 %		
	Stem retracts: activation at ≥19.95 mA (≥99.5 %)				
Operation	Can be deactivated using a jumper		Can be individually activated or deactivated using capacitive keys (P9 or P10)		
Hysteresis	≤1 %		≤0.3 %		
Variable position	≤7 %		-		
Switching accuracy	0.14 mA		-		
Air consumption in steady state	When w = 100 %: 6 bar ≤200 l _n /h · 4 bar ≤160 l _n /h		≤100 l _n /h with a supply pressure up to 6 bar and a signal pressure of 0.6 bar		
Air output capacity	Actuator (supply)	-	At Δp = 6 bar: 8.5 m _n ³ /h At Δp = 1.4 bar: 3.0 m _n ³ /h K _{Vmax} (20 °C) = 0.09		
	Actuator (exhaust)	-	At Δp = 6 bar: 14.0 m _n ³ /h At Δp = 1.4 bar: 4.5 m _n ³ /h K _{Vmax} (20 °C) = 0.15		
Temperature range ²⁾	-30 to +70 °C		-25 to +80 °C ³⁾		
Degree of protection	IP 54 or IP 65 ⁴⁾		IP 66 ⁵⁾		
Electropneumatic or pneumatic connection	Connected inside actuator		Separate from actuator (in the positioner)		
Electromagnetic compatibility	Requirements according to EN 61000-6-2 and EN 61000-6-3		Complying with EN 61000-6-2, EN 61000-6-3 and NAMUR Recommendation NE 21		
Display	-		With LEDs		
Initialization	Manual		Automatic		
Operation	Using screws		Using capacitive keys		
Zero calibration	Without		Automatic (activated by P15 or P16)		
Associated documentation	▶ EB 8313-1		▶ EB 8313-3, ▶ EB 8394 or ▶ T 8394		

¹⁾ Versions with Type 3730-x or Type 3731-x Positioner on request

²⁾ Observe temperature range of mounted devices (positioner etc.).

³⁾ -35 to +90 °C with Type 373x-x Positioner and metal cable glands

⁴⁾ IP 65 only when the vent plug is replaced by a filter check valve (order no. 1790-7408)

⁵⁾ Other ratings possible when a Type 373x-x Positioner is mounted. See corresponding mounting and operating instructions

Table 1.2: Explosion-protection approvals for Type 3372





Type 3372		With integrated i/p converter	With Type 3725 Positioner (direct attachment)		
Actuator area		120 cm ²	120 cm ²	350 cm ²	
Rated travel		15 mm	15 mm	15 mm	30 mm
ATEX 	Number	PTB 99 ATEX 2049	PTB 11 ATEX 2020 X		
	Date	1999-07-06	2011-08-25		
	Type of protection	II 2G Ex ia IIC T6	II 2G Ex ia IIC T4		
CSA Group 	Number	-	2703735 X		
	Date		2014-06-03		
	Type of protection		Ex ia IIC T4; Class I, Zone 0, AEx ia IIC T4; Class I, Div. 1, Groups A, B, C & D		
GOST 	Number	-	RU C-DE.GB08.B.00697		
	Date		2014-12-15		
	Valid until		2019-12-14		
	Type of protection		1Ex ia IIC T4 Gb X		

Table 1.3: Further technical data for Type 3372

Type 3372	With integrated i/p converter				With Type 3725 Positioner (direct attachment)							
Actuator area	120 cm ²				120 cm ²				350 cm ²			
Rated travel	15 mm				15 mm				15 mm		30 mm	
Pneumatic data												
Tight-closing function	Stem retracts (FE)	Stem retracts (FE)	Stem extends (FA)	Stem extends (FA)	Stem retracts (FE)	Stem retracts (FE)	Stem extends (FA)	Stem extends (FA)	Stem retracts (FE)	Stem extends (FA)	Stem retracts (FE)	Stem extends (FA)
Bench range	0.4 to 1.4	1.4 to 2.3		2.1 to 3.3	0.4 to 1.4	1.4 to 2.3		2.1 to 3.3	1.5 to 2.1	2.1 to 2.7	1.5 to 2.7	2.2 to 3.8
Supply pressure	Max. 6 bar	Max. 4 bar		Max. 6 bar	Max. 6 bar ¹⁾				Max. 6 bar			
Materials												
Actuator housing	Aluminum, powder paint coated				Aluminum, powder paint coated				1.0332			
Diaphragm	NBR				NBR				NBR			
Actuator stem	1.4305				1.4305				1.4401/1.4404			
Weight (without positioner)												
kg (approx.)	3.7				3.3				15			
Attachment												
	Form B				Form B or Form C (see Table 2)				Form C			
Conformity												
												

¹⁾ With fail-safe action "actuator stem extends", the supply pressure must not exceed the upper bench range value by more than 1.5 bar.

Table 1.4: Technical data of Type 4744-2 Limit Switch

Type 4744-2 Limit Switch	
Travel range	15 mm
Permissible load	AC voltage: 250 V/5 A DC voltage: 250 V/0.4 A
Temperature range	-20 to +60 °C
Degree of protection	IP 66
Explosion protection	Flameproof enclosure II 2G Ex db IIC T6-T5
Approx. weight	0.4 kg
Associated documentation	► T 8367

Mounting types

There are two types of mounting depending on the valve/actuator combination: mounting using a crossbeam or rods.

When the actuator is mounted to the valve using a crossbeam (form B, Fig. 8), the actuator is fastened to the valve bonnet using a central nut.

When the actuator is mounted using rods (form C, Fig. 9 and Fig. 10), the actuator is connected to the valve bonnet using rods. In this case, a crossbeam is not required for mounting the actuator.

Table 2: Mounting types (see Fig. 8, Fig. 9 and Fig. 10)

Type ... Valve	Valve size DN	Implementation	Integrated i/p converter	Type 3725 Positioner (direct attachment)		
		Actuator area	120 cm ²	120 cm ²	350 cm ²	
		Travel	15 mm	15 mm	15 mm	30 mm
3321	15 to 50	Form B	Form B	-	-	
3321	65 to 100	-	Form C	Form C	-	
3321	100	-	-	-	Form C	
3323	15 to 50	Form B	Form B	-	-	
3323	65 to 80	-	Form C	Form C	-	
3323	100	-	-	-	Form C	
3531	15 to 80	Form B	Form B	-	-	
3535	15 to 80	Form B	Form B	-	-	
3214	65 to 100	Form B	Form B	-	-	
3214	125 to 250	-	-	-	On request	
3260	65 to 80	Form B	Form B	-	-	
3260	100 to 150	-	-	-	Form B	

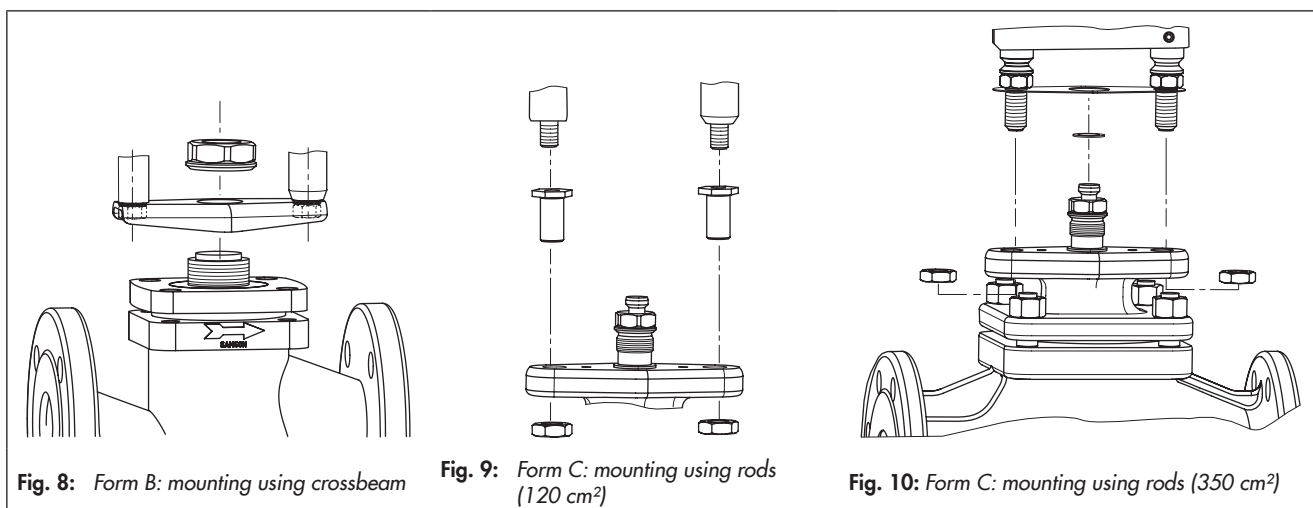

Fig. 8: Form B: mounting using crossbeam

Fig. 9: Form C: mounting using rods (120 cm²)

Fig. 10: Form C: mounting using rods (350 cm²)

Table 3: Bench ranges of Type 3372 Actuator

Actuator area [cm ²]	Rated travel [mm]	Travel volume at rated travel [cm ³]	Bench range [bar] (signal pressure range at rated travel)	Additional possible spring compression	No. of springs	Fail-safe action: actuator stem extends		Fail-safe action: actuator stem retracts				
						Spring force at 0 mm travel [kN]	Spring force at rated travel [kN]	Spring force [kN] at rated travel and supply pressure [bar] of				
								2	3	4	5	6
120	15	1800	0.4 to 1.4	-	4	0.5	1.7	0.7	1.9	3.1	-	-
		1800	1.4 to 2.3		8	1.7	2.8	-	0.8	2	3.2	4.4
		1800	2.1 to 3.3		12	2.5	4.0	-	-	-	-	-
350	15	5250	1.5 to 2.1	-	8	-	-	-	3.15	6.65	6.65	6.65
		5250	2.1 to 2.7		6	7.35	9.5	-	-	-	-	-
	30	10500	1.5 to 2.7		8	-	-	-	1.05	4.55	8.05	11.55
		10500	2.2 to 3.8		12	7.7	13	-	-	-	-	-

Dimension diagrams · All dimensions in mm

With integrated i/p converter

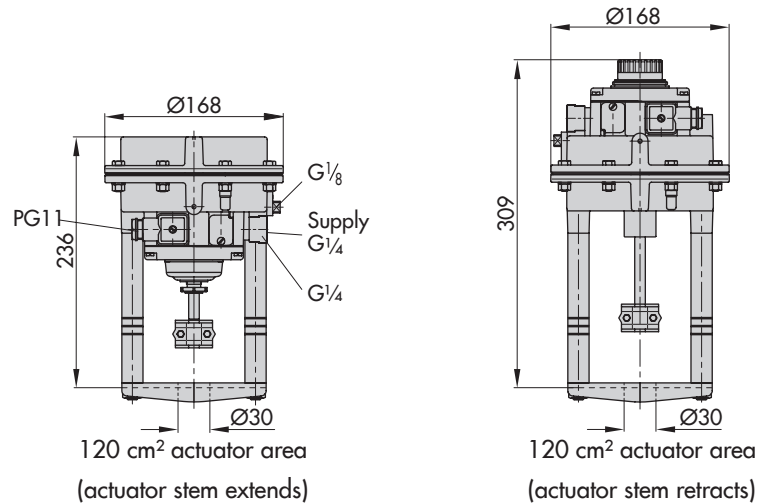

With Type 3725 Positioner (direct attachment)

